



2x10 GPON Transceiver Module
Pigtailed, DDMI, RoHS



FEATURES:

- 2x10 pin SFF package with SC/APC pigtail.
- 1310nm DFB LD BM Transmitter @ 1244.16 Mbps
- 1490nm APD-TIA CM Receiver @ 2488.32 Mbps
- Support DDMI
- WDM filter for Voice/Data FTTx ONT/ONU applications
- Single +3.3V power supply, LVTTTL Bias
- Control input and Rx Signal Detect output
- Operating temperature from 0°C to 70°C
- RoHS compliance

ORDERING INFORMATION

P/N	Mbps	LD/PD	Reach	Vol.	DDM	Burst Control	Temp
G1250-BDA5-D3C3-T3-D	1250	1310nm DFB-LD/ 1490nm APD-TIA	20km via SMF	3.3V	Yes	Enable: Logic "1"	0-70C

G1250= GPON 1250Mbps	BDA5=2X10 SFF BIDI SC/APC Pigtail	D3=DFB 1310nm	T3= SD TTL DC-AC Coupling
		C3=20km, 3.3Volt	D=DDMI Function

APPLICATIONS

- GPON ONU Class B+ for P2MP applications
- FTTx WDM Broadband Access

STANDARDS

- Compliant to ITU-T G.984.2 GPON ONU Class B+
- Compliant to IEC 60825 Class 1
- Compliant to Bellcore GR-468

DESCRIPTION

- The GPON ONU Transceiver module is designed for Gigabit Passive Optical Network (GPON) 20km transmission. The module incorporates 1310nm burst-mode transmitter and 1490nm continuous-mode receiver.
- The transmitter section uses a 1310nm DFB laser and an integrated burst-mode laser driver to perform burst enable/disable delay time. The laser driver also includes digital APC and temperature compensation circuit for keeping the launch optical power and extinction ratio constant over temperature and aging.
- The receiver section uses an integrated 1490nm APD photodiode and preamplifier that indicates receiver signal-detected status (active high).



ABSOLUTE MAXIMUM RATINGS

Parameter	Symbol	Min	Max	Unit	
Operating Case Temperature Range	T _c	0	70	°C	
Storage Temperature Range	T _s	-40	85	°C	
Relative Humidity	RH	5	95	%	
Power Supply Voltage	V _{cc}	0	4.6	V	
Pin Input Voltage		GND	V _{cc}	V	
Receiver Damage Threshold		+4	-	dBm	
Lead Solder Temperature / Duration		-	350 / 5	°C / s	

RECOMMENDED OPERATING CONDITIONS

Parameter	Symbol	Min.	Typ.	Max.	Unit	Note
Operating Case Temperature	T _c	0		+70	°C	
Ambient Humidity		5		90	%	Non-condensing
Power Supply Voltage	V _{cc}	3.13	3.3	3.47	V	
Power Supply Current	I _{cc}			400	mA	

SPECIFICATION OF TRANSMITTER

Parameter	Symbol	Min.	Typ.	Max.	Unit	Note
Average Launched Power (EoL) into SMF	P _o	+0.5		+5	dBm	
Optical Extinction Ratio	ER	9			dB	
Center Wavelength (DFB LD)	λ _c	1260	1310	1360	nm	
-20dB Spectrum Width (RMS)	Δλ		0.3	1	nm	
Side Mode Suppression Ratio	SMSR	30			dB	
Transmitter OFF Output Power	P _{off}			-45	dBm	
Optical Rise/Fall Time (unfiltered 20-80%)	t _r /t _f			260	ps	
Tx Enable / Disable	Ton/ Toff			16	bits	12.8ns
Transmitter Reflectance (1260 to 1360nm)				-6	dB	
Tolerance to the Transmitter's Incident Light Power		-15			dB	
Jitter Generation				0.33	Ulp-p	4KHz~10MHz
Output Eye Mask	Compliant with ITU-T G.984.2					



G1250-BDA5-D3C3-T3-D
SFF 2x10 GPON Class B+ ONU Transceiver
2.488Gbps Downstream/1.244Gbps Upstream



SPECIFICATION OF RECEIVER

Parameter	Symbol	Min.	Typ.	Max.	Unit	Note
Input Optical Wavelength (APD)	λ_{IN}	1480		1550	nm	
Receiver Sensitivity (Measured with 1490nm, ER=10dB; BER =10^{-10} @ PRBS=2 ²³ -1 NRZ without FEC)	P_{IN}			-28	dBm	
Input Saturation Power(Overload)	P_{SAT}	-8			dBm	
Signal Detect-Assert Power	P_A			-28	dBm	
Signal Detect-Deassert Power (When Signal Detect Deasserted, the data output is Low-level)	P_D	-44			dBm	
Signal Detect-Hysteresis	P_A-P_D	0.5	2	6	dB	
Consecutive Identical Bit Immunity		72			bits	
Optical Crosstalk from Internal Laser	X_{opt}			-47	dB	
Tolerance to reflected optical power				10	dB	
Receiver Reflectance (1480~1550nm)				-20	dB	
Output Data Rise/Fall time (20%~80%)	t_r/t_f			150	ps	
Optical Isolation of Receiver (1260~1360nm)		40			dB	

ELECTRICAL INTERFACE CHARACTERISTICS

Parameter	Symbol	Min.	Typ.	Max.	Unit	Note
Transmitter						
Total Supply Current	I_{CC}			A	mA	** (1)
Differential line input Impedance	R_{IN}	90	100	110	Ohm	
Differential Data Input Swing	V_{DT}	200		1800	mV _{p-p}	DC-Coupled
BiasCNT Input Voltage- High	V_{BCNTH}	2		V _{CC}		LVTTTL
BiasCNT Input Voltage- Low	V_{BCNTL}	0		0.8		
Receiver						
Total Supply Current	I_{CC}			B	mA	** (1)
Differential Data Output Swing (CML Interface, AC coupled to 100Ω differential Load)	V_{DR}	400		1200	mV _{p-p}	
Signal Detect Output Voltage- High	V_{LOSH}	2		V _{CC} +0.3	V	LVTTTL
Signal Detect Output Voltage- Low	V_{LOSL}	0		0.8	V	

** (1). A (TX)+ B (RX) = 400mA (Not include termination circuit)



DIGITAL DIAGNOSTIC MONITOR ACCURACY

Parameter	Accuracy	Calibration	Note
Transceiver Internal Temperature	$\pm 3^{\circ}\text{C}$	Internal	$T_A=0\sim+70^{\circ}\text{C}$
Power Supply Internal Voltage	$\pm 3\%$	Internal	$V_{cc}=3.13\sim 3.47\text{V}$
TX Optical Power	$\pm 3\text{dB}$	Internal	+0.5 to +5dBm
TX Bias Current	$\pm 10\%$	Internal	Specified by nominal bias value
RX Optical Power	$\pm 3\text{dB}$	Internal	-28 to -8dBm

ENHANCED DIGITAL DIAGNOSTIC INTERFACE

Following memory map describes an extension defined in SFF-8472 MSA. The enhanced interface uses 1010001X(A2h) to provide diagnostic information of the module operating conditions.

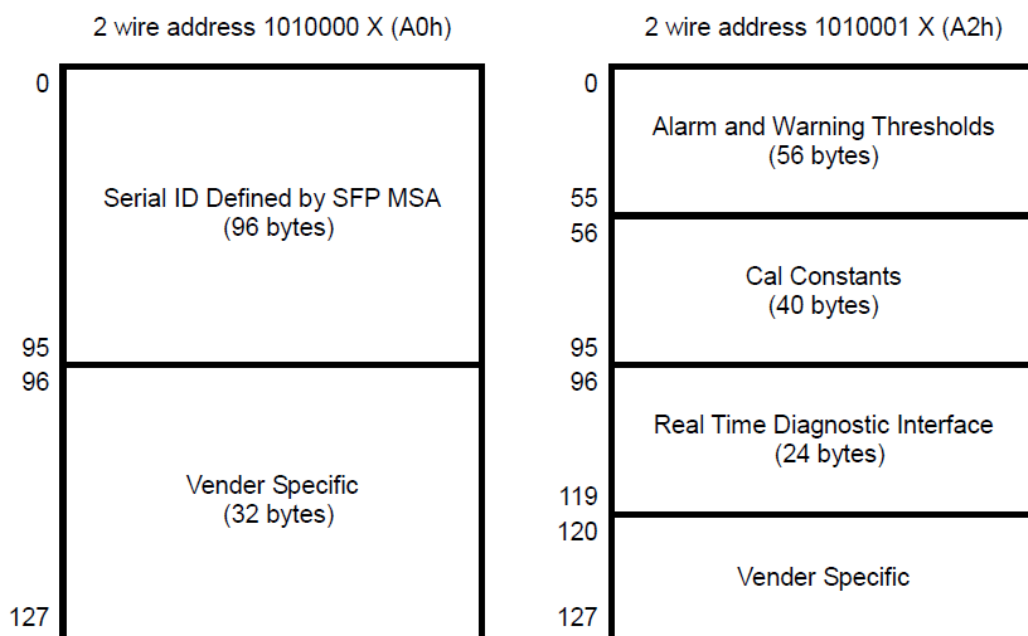



EEPROM Serial ID Memory Contents (2-Wire Address A0h)

Address	Name of Field	Hex	Description
Base ID Fields			
00	Identifier	02	SFF physical device(soldered device)
01	Ext. Identifier	04	Serial ID module supported
02	Connector	0B	Optical pigtail
03-10	Transceiver Codes	00	Undefined
11	Encoding	03	Compatible with NRZ encoding code
12	BR. Nominal	0C	Nominal 1244Mbps
13	Reserved	00	
14	Length (9μm)-km	14	20km @9/125μm fiber
15	Length (9μm)-100m	C8	20000m @9/125μm fiber
16-18	Length for MMF	00	Undefined
19	Reserved	00	
20-35	Vendor Name	57 41 4D 49 4E 20 20 20 20 20 20 20 20 20 20 20	“WAMIN”(ASCII character)
36	Channel Spacing	00	Undefined
37-39	Vendor OUI	00	Undefined
40-55	Vendor P/N	47 31 32 35 30 42 44 41 35 44 33 43 33 54 33 44	(ASCII character) G1250-BDA5-D3C3-T3-D
56-59	Vendor P/N Rev.	20 20	
60-61	Laser Wavelength	05 1E	1310nm in Hex byte
62	DWDM Wavelength Fraction	00	Undefined
63	CC BASE	XX	Check sum of bytes 0-62
Extended ID Fields			
64-65	Options	00 04	Signal Detect is implemented
66	BR. Max.	00	Undefined
67	BR. Min.	00	Undefined
68-83	Vendor SN	SN	Vendor serial number in ASCII character
84-91	Date Code	DC	Vendor date code in ASCII character
92	Diagnostic Monitoring Type	68	Implemented with internal calibration and received power measurement type by Avg. power
93	Enhanced options	C0	Alarm/Warning flags monitor are implemented
94	SFF-8472 compliant	02	SFF-8472 compliant with V. 9.5
95	CC_EXT	XX	Check sum of bytes 64-94
Vendor Specific ID Fields			
96-127	Vendor Specific	00	Vendor specific EEPROM
128-256	Reserved	00	Reserved for future use



DDM Interface (2-Wire Address A2h), Alarm and Warning Thresholds

Address	# Bytes	Name of Field	HEX	Real Value	Unit
00-01	2	Temp High Alarm	55 00	85	C
02-03	2	Temp Low Alarm	FB 00	-5	C
04-05	2	Temp High Warning	50 00	80	C
06-07	2	Temp Low Warning	00 00	0	C
08-09	2	Voltage High Alarm	94 70	3.8	V
10-11	2	Voltage Low Alarm	6D 60	2.8	V
12-13	2	Voltage High Warning	87 8C	3.47	V
14-15	2	Voltage Low Warning	7A 44	3.13	V
16-17	2	Bias High Alarm	75 30	60	mA
18-19	2	Bias Low Alarm	05 DC	3	mA
20-21	2	Bias High Warning	61 A8	50	mA
22-23	2	Bias Low Warning	07 D0	4	mA
24-25	2	TX Power High Alarm	FF FF	—	dBm
26-27	2	TX Power Low Alarm	FF FF	—	dBm
28-29	2	TX Power High Warning	FF FF	—	dBm
30-31	2	TX Power Low Warning	FF FF	—	dBm
32-33	2	RX Power High Alarm	0C 5A	-5	dBm
34-35	2	RX Power Low Alarm	00 08	-31	dBm
36-37	2	RX Power High Warning	06 31	-8	dBm
38-39	2	RX Power Low Warning	00 10	-28	dBm
40-55	16	Reserved	FF FF		

Calibration Constants (2 Wire Address A2h)

Address	# Bytes	Name of Field	HEX	Description
56-59	4	Rx_PWR (4)	00 00 00 00	Set to zero for "internally calibrated" devices.
60-63	4	Rx_PWR (3)	00 00 00 00	Set to zero for "internally calibrated" devices.
64-67	4	Rx_PWR (2)	00 00 00 00	Set to zero for "internally calibrated" devices.
68-71	4	Rx_PWR (1)	3F 80 00 00	Set to 1 for "internally calibrated" devices.
72-75	4	Rx_PWR (0)	00 00 00 00	Set to zero for "internally calibrated" devices.
76-77	2	Tx_I (Slope)	01 00	Set to 1 for "internally calibrated" devices.
78-79	2	Tx_I (Offset)	00 00	Set to zero for "internally calibrated" devices.
80-81	2	Tx_PWR (Slope)	01 00	Set to 1 for "internally calibrated" devices.
82-83	2	Tx_PWR (Offset)	00 00	Set to zero for "internally calibrated" devices.
84-85	2	T (Slope)	01 00	Set to 1 for "internally calibrated" devices.
86-87	2	T (Offset)	00 00	Set to zero for "internally calibrated" devices.
88-89	2	V (Slope)	01 00	Set to 1 for "internally calibrated" devices.
90-91	2	V (Offset)	00 00	Set to zero for "internally calibrated" devices.
92-94	3	Reserved	00 00 00	Reserved
95	1	Checksum	XX	Checksum of bytes 0 - 94.

A/D Value (2 Wire Address A2h)

Address	# Bytes	Name of Field	Description
96-97	2	Temperature (MSB, LSB)	Internally measured module temperature
98-99	2	Supply Voltage (MSB, LSB)	Internally measured supply voltage in module
100-101	2	Tx Bias Current (MSB, LSB)	Internally measured Tx Bias current
102-103	2	Tx Optical Power (MSB, LSB)	Measured Tx Output power
104-105	2	Rx Received Power (MSB, LSB)	Measured Rx input power
106-109	4	Reserved	



Status Bits and Alarm/Warning Flag Bits (2 Wire Address A2h)

Address	Bit	Name	Description
110	7	TX Disable State	Digital state of Tx disable (1) and enabled (0)
110	6	Soft TX Disable	Read/write bit that allows software disable of Tx. Writing 1 disables Tx
110	5-3	Reserved	
110	2	TX Fault State	1=Tx failure state, 0=Tx normal state
110	1	Signal Detect State	Digital state of SD output pin. 1=optical signal detected, 0=no optical signal detected
110	0	Data_Ready_Bar	Not implemented.
111	1-0	Soft Tx Mode	Not implemented.
112	7	Temp High Alarm	Set when internal temperature exceeds high alarm level.
112	6	Temp Low Alarm	Set when internal temperature is below low alarm level.
112	5	Vcc High Alarm	Set when internal supply voltage exceeds high alarm level.
112	4	Vcc Low Alarm	Set when internal supply voltage is below low alarm level.
112	3	TX Bias High Alarm	Set when TX Bias current exceeds high alarm level.
112	2	TX Bias Low Alarm	Set when TX Bias current is below low alarm level.
112	1	TX Power High Alarm	Set when TX power exceeds high alarm level.
112	0	TX Power Low Alarm	Set when TX power exceeds low alarm level.
113	7	RX Power High Alarm	Set when Received Power exceeds high alarm level.
113	6	RX Power Low Alarm	Set when Received Power is below low alarm level.
113	5-0	Reserved Alarm	
114-115	All	Reserved	
116	7	Temp High Warning	Set when internal temperature exceeds high warning level.
116	6	Temp Low Warning	Set when internal temperature is below low warning level.
116	5	Vcc High Warning	Set when internal supply voltage >high warning level.
116	4	Vcc Low Warning	Set when internal supply voltage < low warning level.
116	3	TX Bias High Warning	Set when TX Bias current exceeds high warning level.
116	2	TX Bias Low Warning	Set when TX Bias current is below low warning level.
116	1	TX Power High Warning	Set when TX power exceeds high warning level.
116	0	TX Power Low Warning	Set when TX power exceeds low warning level.
117	7	RX Power High Warning	Set when Received Power exceeds high warning level.
117	6	RX Power Low Warning	Set when Received Power is below low warning level.
117	5-0	Reserved Warning	
118-119	All	Reserved	

Vendor Specific and User Accessible EEPROM (2 Wire Address A2h)

Address	# Bytes	Name	Description
120-122	3	Reserved	
123	1	Password Byte 3	High order byte of 32 bit password
124	1	Password Byte 2	Second highest order byte of 32 bit password
125	1	Password Byte 1	Second lowest order byte of 32 bit password
126	1	Password Byte 0	Low order byte of 32 bit password
127	1	User EEPROM Select	"1" selects user writable EEPROM at locations 128-247
128-255	128	Reserved	Reserved for future use



Pin Description

Tx/Rx	Pin No.	I/O	Pin Name	Description
Rx	1		NC	No Function Definition
	2		V _{CCR}	Receiver Ground
	3		V _{CCR}	Receiver Ground
	4		NC	No Function Definition
	5		NC	No Function Definition
	6		VeeR	Receiver Ground
	7		V _{CCR}	Receiver Power Supply
	8	O	SD	Normal Optical Input indicated by logic "High", and No Optical Input indicated by logic "Low".
	9	O	RD(-)	Inverted Receiver Data Output (AC-Coupled internally)
	10	O	RD(+)	Non-Inverted Receiver Data Output (AC-Coupled internally)
Tx	11		V _{CCT}	Transmitter Power Supply
	12		V _{EET}	Transmitter Ground
	13	I	BiasCNT	LVTTTL Logic "High" to Enable Burst Transmitter, and Disable Burst Transmitter by Logic "Low".
	14	I	TD(+)	Non-Inverted Transmitter Data Input (DC-Coupled)
	15	I	TD(-)	Inverted Transmitter Data Input (DC-Coupled)
	16		V _{EET}	Transmitter Ground
	17	I	SCL	I2C Serial Clock (LVTTTL)
	18	I/O	SDA	I2C Serial Data (LVTTTL)
	19	I	Reset	MicroProcessor Reset, Active Low (LVTTTL)
20		V _{EET}	Transceiver Ground	
MS			MS	Mounting Studs/Connect this pin to Chassis ground

Outline Dimensions

Parameter	Unit	Description	Note
Mechanical Dimensions	mm	~49.0x13.6x9.9	
Connector Type	-	SC/APC	
Fiber length (L)	mm	600±20	

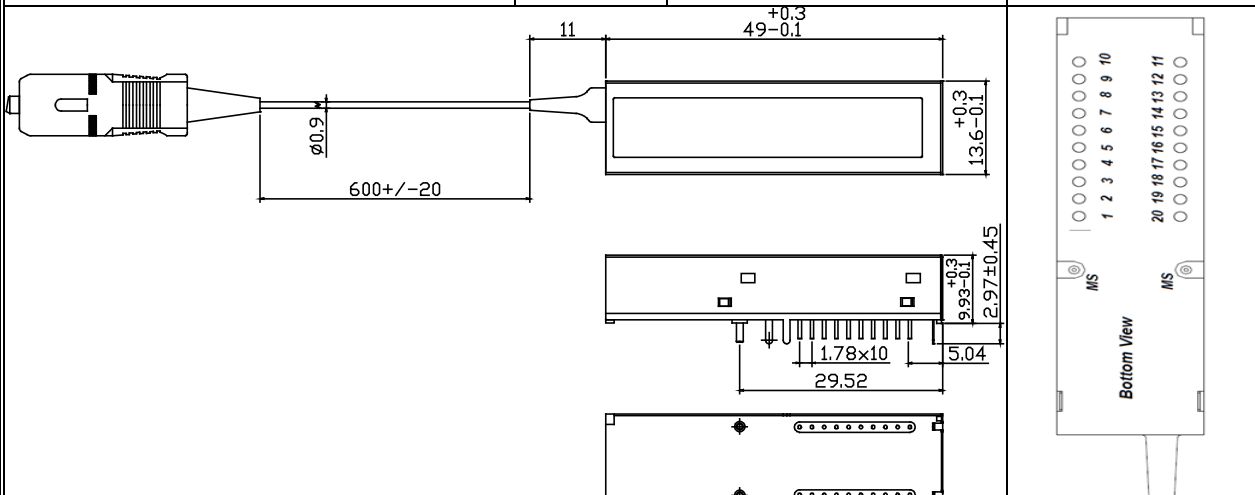



Recommended Interface Circuit (please enlarge to view)

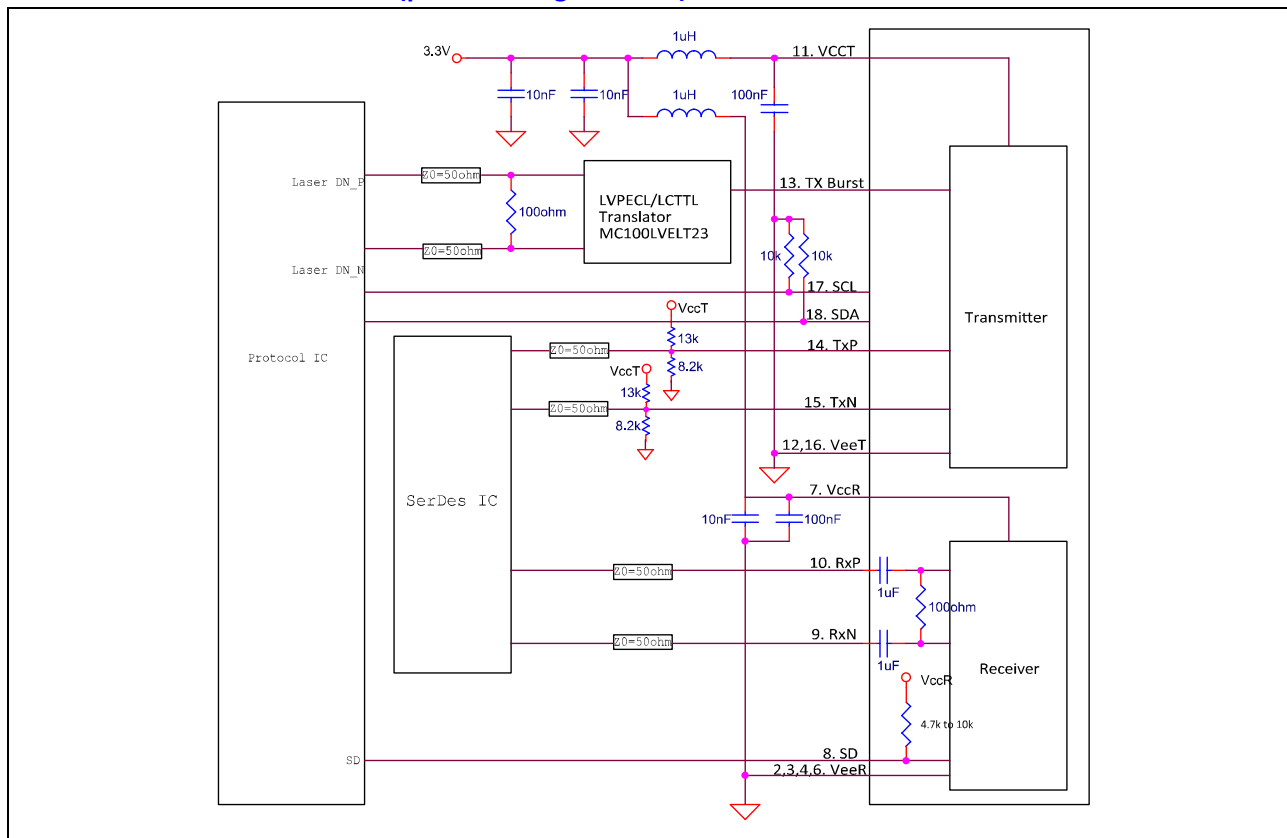

REGULATORY COMPLIANCES

Feature	Test Method	Reference	Performance
Electrostatic Discharge (ESD) to the Electrical Pins	Human Body Model (HBM)	MIL-STD-883E Method 3015.7 EIA-JESD22-A114	(1) Satisfied with electrical characteristics of product spec. (2) No physical damage
	Machine Model (MM)	EIA-JESD22-A115	
Electrostatic Discharge (ESD) to the Simplex Receptacle	Contact Discharge	IEC/EN 61000-4-2	
	Air Discharge	IEC/EN 61000-4-2	
Radio Frequency Electromagnetic Field Immunity		IEC/EN 61000-4-3	
Electromagnetic Interference (EMI)		FCC Part 15 Class B EN 55022 Class B (CISPR 22A)	
Laser Eye Safety	FDA/CDRH TUV	FDA21CFR 1040.10, 1040.11 IEC/EN 60825-1 IEC/EN 60825-2	
Component Recognition	TUV UL/CSA	IEC/EN 60950 UL60950	

- ❖ For more information, please e-mail sales@wamin.com.tw
- ❖ The information and datasheets above are subject to change without prior notice.
- ❖ Document No.: SPC 10050-3 V.01